

- **Due Woofer in Neodimio da 320mm in cabinet reflex**
- **Driver Titanio/Neodimio da 75mm/Tromba AF (80° x 60°)**
- **Sistema di sospensione incluso**
- **Pilotaggio passivo o BI-AMP (passivo BF/AF)**
- **Per usi portatili o installazioni permanenti**

PSAT1 è stato progettato per soddisfare gli utilizzatori professionali. Elevata pressione sonora, bassa distorsione e alta tenuta in potenza lo rendono ideale come sistema principale in concerti e riproduzioni di musica dal vivo o, in alternativa, un superbo sistema di front o side fill. Il sistema di sospensione incluso nel cabinet permette l'utilizzo in array o installazioni fisse.

- **Two Neodimium woofer of 320mm in vented Enclosure**
- **75mm Neodimium/Titanium driver/Horn-loaded (80°x 60°)**
- **Fly mounting points**
- **Powering mode full range passive or BI-AMP (passive MF/HF)**
- **For touring or fixed installation**

The PSAT1 was designed to support the widest possible range of pro audio applications.

Its high output capabilities let it act as a main system for concert or even provide front or side fill for concert touring applications.

The comprehensive system mounting points permit safe, suspension in permanent installations.

PSAT1



TWO WAY LOUDSPEAKER SYSTEM

Product Information

LSS PSAT1 è un diffusore acustico a 2 vie reflex con sezione medio alta caricata a tromba a bassa distorsione.

PSAT1 è costituito da due woofer da 320 mm con bobina da 75mm a lunga corsa con magneti in Neodimio, e un driver da 75mm con membrana in Titanio e magneti in Neodimio.

Lo stesso è accoppiato ad una tromba in Alluminio a direttività costante ruotabile dalla dispersione 80°X60°.

PSAT1 Può essere pilotato in modo passivo a gamma intera o bi-amp grazie al circuito crossover passivo incluso comprensivo di protezione dinamica professionale Tw Guard

LSS's PSAT1 2-way loudspeaker system provides high output, low distortion sound reinforcement for the entire range of pro audio applications.

The two 320 mm low frequency cone with 75mm voice coil with Neodimium magnet and 75mm Titanium voice coil with Neodimium high frequency compression driver provides higher output and lower distortion plus enhanced power handling capabilities for better performance in touring applications.

LSS's advanced crossover included professional protection of HF TW GUARD.

The PSAT1 offers a switchable powering mode: passive operation using the internal crossover filter network or bi-amplified operation.



LSS Advanced Speakers Systems

Via On. Longo 53 - 89024 Polistena (RC) ITALY
Tel. (39) 966 932199 - Fax (39) 966 933007
Email: lss@lss.it - Internet: www.lss.it

www.lss.it

PSAT1

2-WAY LOUDSPEAKER SYSTEM

Data Sheet

Physical

Dimensions mm (± 1 mm)

- Height **1000**
- Front Width **400**
- Rear Width **210**
- Depth **585**
- Trapezoid Angle (degrees) **9° per side**

Weights Kilograms

- Net Weight **55**
- Shipping Weight **62**
- System Configuration **2way full range**

Enclosure Material

- Enclosure material **Birch Plywood of 18mm**
- Finish **Texture poliuretanic black paint**
- Suspension **6 point mounting suspension**
- Grille **Poweder coated perforated steel**
- Connectors **Two Neutrik NL4 speakon**
- Optional Accessories **Fly clip with ring**

Performance

Frequency Response

- ± 5 dB **50Hz to 18KHz**
- -10 dB **45Hz**

Sensitivity (dB 1 watt @ 1 m)

- Full Range Passive **100dB**
- LF **100dB**
- HF **106dB**

Nominal Input Impedance (ohms)

- Full Range Passive **4**
- LF **4**
- HF **16**

Power Handling (watts cont. AES)

- Full Range Passive **1000**
- LF **800**
- HF **200**

SPL (referenced to 1 m 1w)

- Full Range Passive **100dB**

Nominal Dispersion (degrees @ - 6 dB)

- Horizontal **80°**
- Vertical **60°**

- Product Series **PSAT**
- LF Subsystem & Loading **Two 320mm woofer vented**
- HF Subsystem & Loading **One 36mm exit/75mm voice coil**
- Crossover 2 way **12/18dB**
- Sistem Protection **TW Guard**
- Operating Mode **Passive or BI AMP (passive LF/HF)**

Additional Date

Dimensions

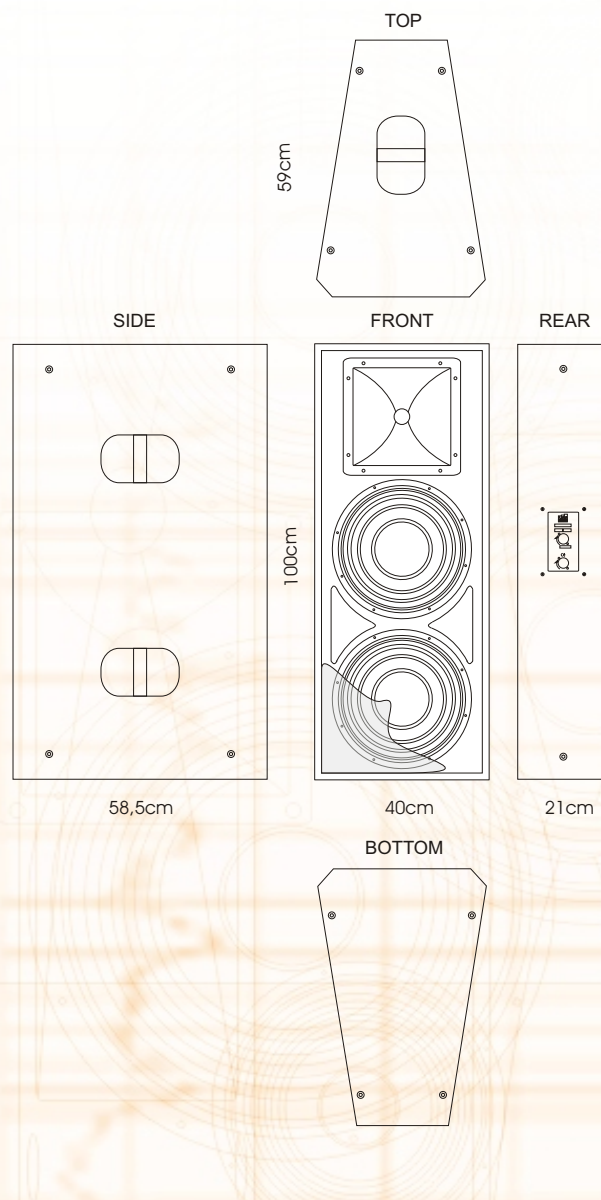

LSS Advanced Speakers Systems

Via On. Longo 53 - 89024 Polistena (RC) ITALY
Tel. (39) 966 932199 - Fax (39) 966 933007
Email: lss@lss.it - Internet: www.lss.it