

- **Woofers 100mm in cabinet reflex**
- **Tweeter 20mm a cupola morbida**
- **Sistema di sospensione incluso**
- **Pilotaggio full range passivo**
- **Per installazioni permanenti**

LSS SP110 è un diffusore acustico ideale per impianti di sonorizzazione distribuiti. Il Cabinet trapezoidale inclinato di 13° consente la creazione di piccoli grappoli. SP 110 può essere ideale per applicazioni audio video, sonorizzazioni di piccoli e medi locali, etc. I punti di aggancio compresi nel mobile facilitano la sospensione permanente in installazioni fisse.

- **100mm LF in vented enclosure**
- **20mm Dome tweeter shielded**
- **Fly mounting points included**
- **Powering mode full range passive**
- **For permanent installations**

The SP110 system is ideal for distributed systems, the 13° per side trapezoid angles match the 60° horizontal coverage pattern allowing the creation of tight packed clusters. It is ideal for sound reinforcement in A/V events. The comprehensive system mounting points permit safe, suspension in permanent installations.

SP110

COMPACT 2-WAY LOUDSPEAKER SYSTEM



Product Information

LSS SP110 è un diffusore acustico a due vie il primo e il più piccolo della serie SP. Questo piccolo diffusore riproduce dalla linearità hi-fi ma e prestazioni professionali utilizzabile sia come sistema a gamma intera sia come satellite da accoppiare ad un sub woofer (es. PULCEW o SUB Sm1). SP110 utilizza un mid woofer da 100 mm schermato e un Tweeter da 20mm a cupola morbida anch'esso schermato. Il crossover passivo a bassa tolleranza con pendenza 12db e il circuito di protezione Poliswitch garantiscono la massima affidabilità.

LSS's SP110 2-way loudspeaker system it's the first small enclosure to the SP Series. This speaker is able to reproduce hi-fi-like professional sound. The bass reflex trapezoidal cabinet houses one 100 shield mid-woofer and one 20mm soft dome shield tweeter. this loudspeakers, is designed to work in full range mode or to be supported by the PULCEW subwoofer below 100 Hz



LSS Advanced Speakers Systems

Via On. Longo 53 - 89024 Polistena (RC) ITALY
Tel. (39) 966 932199 - Fax (39) 966 933007
Email: lss@lss.it - Internet: www.lss.it

SP110

Dimensions

COMPACT 2-WAY LOUDSPEAKER SYSTEM

Data Sheet

Physical

Dimensions mm (± 1 mm)

- Height 270
- Front Width 150
- Rear Width 80
- Depth 170
- Trapezoid Angle (degrees) **13° per side**

Weights Kilograms

- Net Weight 3
- Shipping Weight 3.5
- System Configuration **2way full range**

Enclosure Material

- Enclosure material MDF of 14mm
- Finish **Texture poliuretanic black paint**
- Suspension **5 point mounting suspension**
- Grille **Powder coated perforated steel**
- Connectors **Black and Red Clamps**
- Optional Accessories **Fly clip with ring**

Performance

Frequency Response

- ± 5 dB 80Hz to 20Kz
- -10 dB 65Hz

Sensitivity (dB 1 watt @ 1 m)

- Full Range Passive **90dB**
- LF **90dB**
- HF **91dB**

Nominal Input Impedance (ohms)

- Full Range Passive **8**
- LF **8**
- HF **8**

Power Handling (watts cont. AES)

- Full Range Passive 50
- LF 50
- HF **20**

SPL (referenced to 1 m 1w)

- Full Range Passive **90dB**

Nominal Dispersion (degrees @ - 6 dB)

- Horizontal **60°**
- Vertical **45°**

- Product Series **SP**
- LF Subsystem & Loading **One 100mm woofer shielded vented**
- HF Subsystem & Loading **One 20mm dome shielded Tweeter**
- Crossover 2 way **12/12dB**
- Sistem Protection Poliswitch

Additional Date

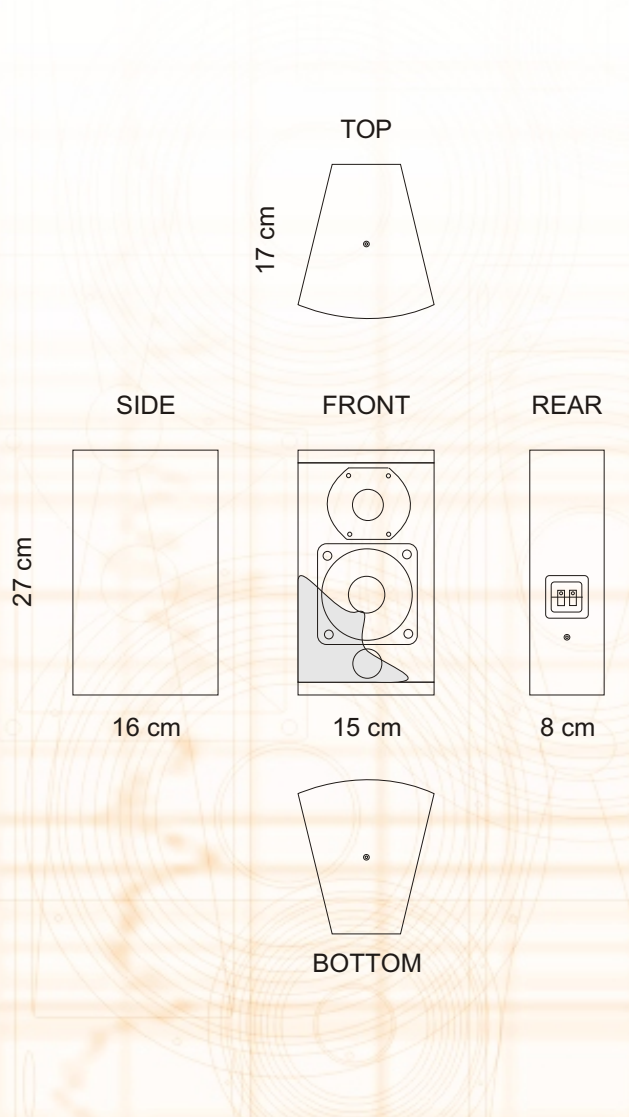

LSS Advanced Speakers Systems

Via On. Longo 53 - 89024 Polistena (RC) ITALY
Tel. (39) 966 932199 - Fax (39) 966 933007
Email: lss@lss.it - Internet: www.lss.it