

# TSM14

## HIGH OUTPUT COAXIAL STAGE MONITOR



### KEY FEATURES

LSS strongly believe in the 14" size transducer, with the new features possible with the newest technologies in magnet and transducer assembly. It offer a great response with natural sound in the mid frequencies like smaller speakers but with a great performance on the bass like a 15".

### OPTIMIZED CROSSOVER FOR PERFECT HIGH SPL PERFORMANCE WITH LESS FEEDBACK RISK

### TECHNICAL INFO

TSM14 is a 2-WAY COAXIAL loudspeaker system designed to support the widest possible range of pro audio applications. High output vocal presence and neutral balanced sound, ideal for stage monitor applications.

It is a state of art stage monitor with a very high output. The 14" coaxial speaker offer a combination of a better low frequency output than a 12- inch, but more balanced midrange performance than a 15-inch. Incredible SPL, exceptional vocal reproduction, and very low frequency reproduction from a small enclosure. Better performance in both touring and permanently installed applications.

LF SECTION: 359 mm (14.13 ") Glass Fiber reinforced low frequency cone, 88 mm (3,5") Aluminium Winding voice coil, Glass Fiber former, Aluminium demodulating ring, double silicone spider, Neodymium ring magnet

HF SECTION: 75 mm (3") voice coil, Pure Titanium Diagram, Aluminiumwinding, kaptonformer.

LSS's advanced crossover includes professional protection of HF.

POWERING MODE passive operation using the internal crossover filter network or on request Bi-Amp operation.

FREQUENCY RESPONSE	±5 dB 50 Hz ~ 18 kHz -10 dB 40 Hz
SENSIVITY <small>(1 Watt @ 1 m)</small>	99 dB
Max SPL Calculated power AES [PEAK]	127 dB 132 dB
NOMINAL IMPEDANCE (Ω)	8 Ω
POWER HANDLING Watts Cont. AES [PEAK Power]	600 W 1800 W
NOMINAL DISPERSION <small>(±6 dB)</small>	80°(H) x 80°(V)
DIMENSIONS mm (±1 mm) (H x W x D)	350 x 580 x 570
WEIGHT	22 Kg

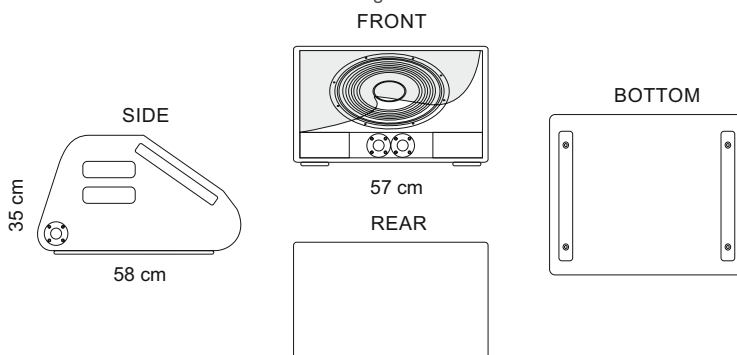

### THE EXPERTS 2CENTS: TONY SODDU

"From my career start my goal was always to get the best from transducers, today with the technology available it is possible to build professional speaker that sounds already very well without artifices."

TSM 14 was deeply tested in cooperation with a professional audio team driven from Tony Soddu, international stage manager with 30 yrs experience. TSM 14 has a lot of "secrets" inside, such as antivibration structure for perfect stage insulation, passive crossover with specific antiresonance cuts, optimized shape for near field work (less than 1,5 mt). "No digital stuff but real acoustic tools to start with a perfect sounding tool"